

EMC-OPTIMIZED CAN TRANSCEIVER

FEATURES

- Qualified for Automotive Applications
- Customer-Specific Configuration Control Can Be Supported Along With Major-Change Approval
- Improved Drop-In Replacement for TJA1040
- Meets or Exceeds the Requirements of ISO 11898-5
- GIFT/ICT Compliant
- ESD Protection up to ± 8 kV (Human-Body Model) on Bus Pins
- Low-Current Standby Mode With Bus Wake-Up, $<12 \mu\text{A}$ Max
- High Electromagnetic Immunity (EMI)
- Low Electromagnetic Emissions (EME)
- Bus-Fault Protection of -27 V to 40 V
- Dominant Time-Out Function
- Thermal Shutdown Protection
- Power-Up/Down Glitch-Free Bus Inputs and Outputs
 - High Input Impedance With Low V_{CC}
 - Monotonic Outputs During Power Cycling

APPLICATIONS

- GMW3122 Dual-Wire CAN Physical Layer
- SAE J2284 High-Speed CAN for Automotive Applications
- SAE J1939 Standard Data Bus Interface
- ISO 11783 Standard Data Bus Interface
- NMEA 2000 Standard Data Bus Interface
- Industrial Automation
 - DeviceNet™ Data Buses (Vendor ID #806)

DESCRIPTION

The SN65HVD1040 meets or exceeds the specifications of the ISO 11898 standard for use in applications employing a Controller Area Network (CAN). The device is qualified for use in automotive applications.

As a CAN transceiver, this device provides differential transmit capability to the bus and differential receive capability to a CAN controller at signaling rates up to 1 megabit per second (Mbps)⁽¹⁾.

(1) The signaling rate of a line is the number of voltage transitions that are made per second, expressed in the units bps (bits per second).

FUNCTIONAL BLOCK DIAGRAM

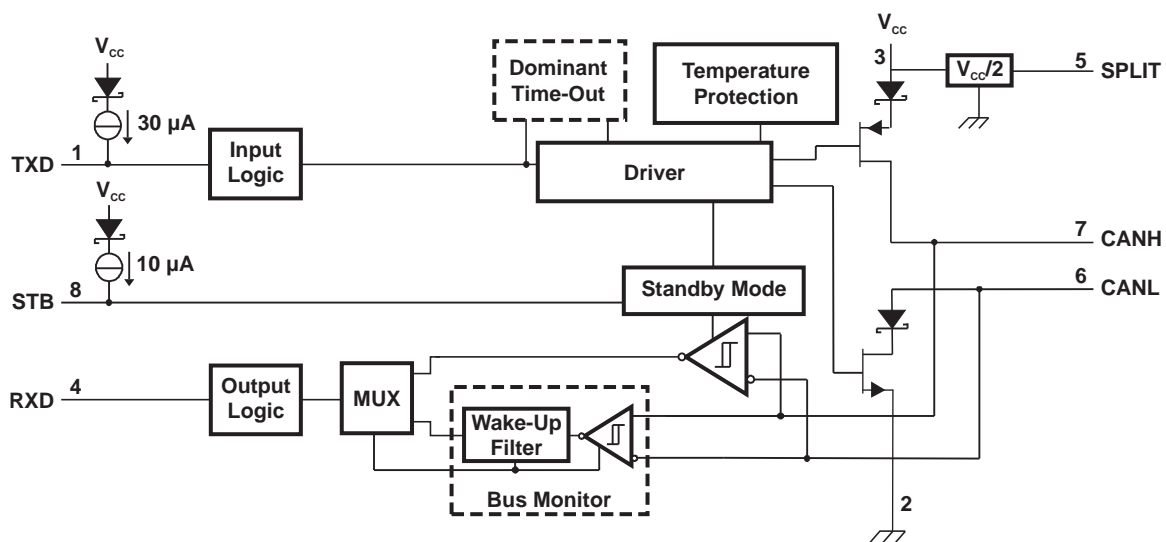

Please be aware that an important notice concerning availability, standard warranty, and use in critical applications of Texas Instruments semiconductor products and disclaimers thereto appears at the end of this data sheet.

DeviceNet is a trademark of Texas Instruments.
All other trademarks are the property of their respective owners.



These devices have limited built-in ESD protection. The leads should be shorted together or the device placed in conductive foam during storage or handling to prevent electrostatic damage to the MOS gates.

DESCRIPTION (CONTINUED)

Designed for operation in especially harsh environments, the SN65HVD1040 features cross-wire, over-voltage, and loss of ground protection from -27 V to 40 V , over-temperature protection, a -12-V to 12-V common-mode range, and withstands voltage transients from -200 V to 200 V , according to ISO 7637.

STB (pin 8) provides two different modes of operation: high-speed mode or low-current standby mode. The high-speed mode of operation is selected by connecting STB (pin 8) to ground.

If a high logic level is applied to the STB pin of the SN65HVD1040, the device enters a low-current standby mode, while the receiver remains active in a low-power bus-monitor standby mode.

In the low-current standby mode, a dominant bit greater than $5\ \mu\text{s}$ on the bus is passed by the bus-monitor circuit to the receiver output. The local protocol controller may then reactivate the device when it needs to transmit to the bus.

A dominant time-out circuit in the SN65HVD1040 prevents the driver from blocking network communication with a hardware or software failure. The time-out circuit is triggered by a falling edge on TXD (pin 1). If no rising edge is seen before the time-out constant of the circuit expires, the driver is disabled. The circuit is then reset by the next rising edge on TXD.

SPLIT (pin 5) is available as a $V_{CC}/2$ common-mode bus voltage bias for a split-termination network (see application information).

The SN65HVD1040 is characterized for operation from -40°C to 125°C .

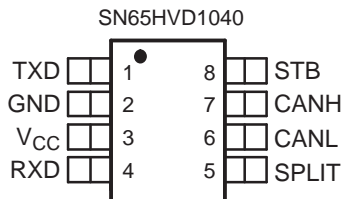

ORDERING INFORMATION⁽¹⁾

PART NUMBER	PACKAGE ⁽²⁾	MARKED AS	ORDERING NUMBER
SN65HVD1040-Q1	SOIC-8	H1040Q	SN65HVD1040QDRQ1 (reel)

(1) For the most current package and ordering information, see the Package Option Addendum at the end of this document, or see the TI web site at www.ti.com.

(2) Package drawings, thermal data, and symbolization are available at www.ti.com/packaging.

Application Hint: CAN Nodes Using Common-Mode Chokes

The SN65HVD1040 has been EMC optimized to allow use in CAN systems without a common-mode choke. However, sometimes the CAN network and termination architecture may require their use. If a common-mode choke is used in a CAN node where bus line shorts to dc voltages may be possible, care should be taken in the choice of common-mode choke (winding type, core type, and value) along with the termination and protection scheme of the node and bus. During CAN bus shorts to dc voltages the inductance of the common-mode choke may cause inductive flyback transients. Some combinations of common-mode chokes, bus termination, and shorting voltages can take the bus voltages outside the absolute maximum ratings of the device, possibly leading to damage.

ABSOLUTE MAXIMUM RATINGS⁽¹⁾⁽²⁾

over operating free-air temperature range (unless otherwise noted)

	VALUE
V_{CC} Supply voltage range	−0.3 V to 7 V
Voltage range at bus terminals (CANH, CANL, SPLIT)	−27 V to 40 V
I_O Receiver output current	20 mA
V_I Voltage input range, ac transient pulse ⁽³⁾ (CANH, CANL)	−200 V to 200 V
V_I Voltage input range (TXD, STB)	−0.5 V to 6 V
T_J Junction temperature range	−40°C to 170°C
T_A Operating free-air temperature range	−40°C to 125°C

- (1) Stresses beyond those listed under "absolute maximum ratings" may cause permanent damage to the device. These are stress ratings only, and functional operation of the device at these or any other conditions beyond those indicated under "recommended operating conditions" is not implied. Exposure to absolute-maximum-rated conditions for extended periods may affect device reliability.
- (2) All voltage values, except differential I/O bus voltages, are with respect to network ground terminal.
- (3) Tested in accordance with ISO 7637-1, test pulses 1, 2, 3a, 3b, 5, 6, and 7. ISO 7637-1 transient tests are ac only; if dc may be coupled in with ac transients, externally protect the bus pins within the absolute maximum voltage range at any bus terminal (−27 V to 40 V). If common-mode chokes are used in the system and the bus lines may be shorted to dc, ensure that the choke type and value in combination with the node termination and shorting voltage either does not create inductive flyback outside of voltage maximum specification or use an external transient-suppression circuit to protect the transceiver from the inductive transients.

ELECTROSTATIC DISCHARGE PROTECTION

over operating free-air temperature range (unless otherwise noted)

PARAMETER	TEST CONDITIONS	VALUE	
Electrostatic discharge ⁽¹⁾	Human-Body Model ⁽²⁾	Bus terminals (CANH, CANL, SPLIT) and GND	±8 kV
		All pins	±4 kV
	Charged-Device Model ⁽³⁾	All pins	±1 kV
		Machine Model	±200 V

- (1) All typical values at 25°C.
- (2) Tested in accordance JEDEC Standard 22, Test Method A114-A.
- (3) Tested in accordance JEDEC Standard 22, Test Method C101.

RECOMMENDED OPERATING CONDITIONS

		MIN	MAX	UNIT
V_{CC}	Supply voltage	4.75	5.25	V
V_I or V_{IC}	Voltage at any bus terminal (separately or common mode)	−12	12	V
V_{IH}	High-level input voltage	TXD, STB		V
V_{IL}	Low-level input voltage	TXD, STB		V
V_{ID}	Differential input voltage	−6	6	V
I_{OH}	High-level output current	Driver	−70	mA
		Receiver	−2	
I_{OL}	Low-level output current	Driver	70	mA
		Receiver	2	
T_J	Junction temperature	See Thermal Characteristics table		150 °C

SUPPLY CURRENT

over recommended operating conditions including operating free-air temperature range (unless otherwise noted)

PARAMETER	TEST CONDITIONS	MIN	TYP	MAX	UNIT	
I_{CC} 5-V supply current	Standby mode	STB at V_{CC} , $V_I = V_{CC}$		6	12	μA
	Dominant	$V_I = 0$ V, 60-Ω load, STB at 0 V		50	70	mA
	Recessive	$V_I = V_{CC}$, No load, STB at 0 V		6	10	

DEVICE SWITCHING CHARACTERISTICS

over recommended operating conditions including operating free-air temperature range (unless otherwise noted)

PARAMETER		TEST CONDITIONS	MIN	MAX	UNIT
$t_{d(LOOP1)}$	Total loop delay, driver input to receiver output, recessive to dominant	STB at 0 V, See Figure 9	90	230	ns
$t_{d(LOOP2)}$	Total loop delay, driver input to receiver output, dominant to recessive		90	230	ns

DRIVER ELECTRICAL CHARACTERISTICS

over recommended operating conditions including operating free-air temperature range (unless otherwise noted)

PARAMETER		TEST CONDITIONS	MIN	TYP ⁽¹⁾	MAX	UNIT
$V_{O(D)}$	Bus output voltage (dominant)	CANH	2.9	3.4	4.5	V
		CANL				
$V_{O(R)}$	Bus output voltage (recessive)	$V_I = 0$ V, STB at 0 V, $R_L = 60$ Ω , See Figure 1 and Figure 2	2	2.5	3	V
V_O	Bus output voltage (standby mode)	STB at V_{CC} , $R_L = 60$ Ω , See Figure 1 and Figure 2	-0.1		0.1	V
$V_{OD(D)}$	Differential output voltage (dominant)	$V_I = 0$ V, $R_L = 60$ Ω , STB at 0 V, See Figure 1, Figure 2, and Figure 3	1.5		3	V
		$V_I = 0$ V, $R_L = 45$ Ω , STB at 0 V, See Figure 1, Figure 2, and Figure 3	1.4		3	
$V_{OD(R)}$	Differential output voltage (recessive)	$V_I = 3$ V, STB at 0 V, $R_L = 60$ Ω , See Figure 1 and Figure 2	-0.012		0.012	V
		$V_I = 3$ V, STB at 0 V, No load	-0.5		0.05	
V_{SYM}	Output symmetry (dominant or recessive) ($V_{O(CANH)} + V_{O(CANL)}$)	STB at 0 V, $R_L = 60$ Ω , See Figure 13	0.9 V_{CC}	V_{CC}	1.1 V_{CC}	V
$V_{OC(ss)}$	Steady-state common-mode output voltage	STB at 0 V, $R_L = 60$ Ω , See Figure 8	2	2.5	3	V
$\Delta V_{OC(ss)}$	Change in steady-state common-mode output voltage	STB at 0 V, $R_L = 60$ Ω , See Figure 8		30		mV
I_{IH}	High-level input current, TXD input	V_I at V_{CC}	-2		2	μ A
I_{IL}	Low-level input current, TXD input	V_I at 0 V	-50		-10	μ A
$I_{O(off)}$	Power-off TXD output current	V_{CC} at 0 V, TXD at 5 V			1	μ A
$I_{OS(ss)}$	Short-circuit steady-state output current	$V_{CANH} = -12$ V, CANL open, See Figure 11	-120	-85		mA
		$V_{CANH} = 12$ V, CANL open, See Figure 11		0.4	1	
		$V_{CANL} = -12$ V, CANH open, See Figure 11	-1	-0.6		
		$V_{CANL} = 12$ V, CANH open, See Figure 11		75	120	
C_O	Output capacitance	See receiver input capacitance				

(1) All typical values are at 25°C with a 5-V supply.

DRIVER SWITCHING CHARACTERISTICS

over recommended operating conditions including operating free-air temperature range (unless otherwise noted)

PARAMETER		TEST CONDITIONS	MIN	TYP	MAX	UNIT
t_{PLH}	Propagation delay time, low-to-high level output	STB at 0 V, See Figure 4	25	65	120	ns
t_{PHL}	Propagation delay time, high-to-low level output	STB at 0 V, See Figure 4	25	45	120	ns
t_r	Differential output signal rise time	STB at 0 V, See Figure 4		25		ns
t_f	Differential output signal fall time	STB at 0 V, See Figure 4		45		ns
t_{en}	Enable time from standby mode to dominant	See Figure 7			10	μ s
$t_{(dom)}$	Dominant time out	$\downarrow V_I$, See Figure 10	300	450	700	μ s

RECEIVER ELECTRICAL CHARACTERISTICS

over recommended operating conditions including operating free-air temperature range (unless otherwise noted)

PARAMETER		TEST CONDITIONS	MIN	TYP ⁽¹⁾	MAX	UNIT
V _{IT+}	Positive-going input threshold voltage, high-speed mode	STB at 0 V, See Table 1		800	900	mV
V _{IT-}	Negative-going input threshold voltage, high-speed mode	STB at 0 V, See Table 1	500	650		mV
V _{hys}	Hysteresis voltage (V _{IT+} – V _{IT-})		100	125		mV
V _{IT}	Input threshold voltage, standby mode	STB at V _{CC}	500		1150	mV
V _{OH}	High-level output voltage	I _O = –2 mA, See Figure 6	4	4.6		V
V _{OL}	Low-level output voltage	I _O = 2 mA, See Figure 6		0.2	0.4	V
I _{I(off)}	Power-off bus input current	CANH = CANL = 5 V, V _{CC} at 0 V, TXD at 0 V			3	μA
I _{O(off)}	Power-off RXD leakage current	V _{CC} at 0 V, RXD at 5 V			20	μA
C _I	Input capacitance to ground (CANH or CANL)	TXD at 3 V, V _I = 0.4 sin (4E6πt) + 2.5 V		12		pF
C _{ID}	Differential input capacitance	TXD at 3 V, V _I = 0.4 sin (4E6πt)		2		pF
R _{ID}	Differential input resistance	TXD at 3 V, STB at 0 V	30		80	kΩ
R _{IN}	Input resistance (CANH or CANL)	TXD at 3 V, STB at 0 V	15	30	40	kΩ
R _{I(m)}	Input resistance matching [1 – (R _{IN (CANH)} / R _{IN (CANL)})] × 100%	V _(CANH) = V _(CANL)	–3	0	3	%

(1) All typical values are at 25°C with a 5-V supply.

RECEIVER SWITCHING CHARACTERISTICS

over recommended operating conditions including operating free-air temperature range (unless otherwise noted)

PARAMETER		TEST CONDITIONS	MIN	TYP	MAX	UNIT
t _{PLH}	Propagation delay time, low-to-high-level output	STB at 0 V, See Figure 6	60	90	130	ns
t _{PHL}	Propagation delay time, high-to-low-level output	STB at 0 V, See Figure 6	45	70	130	ns
t _r	Output signal rise time	STB at 0 V, See Figure 6		8		ns
t _f	Output signal fall time	STB at 0 V, See Figure 6		8		ns
t _{BUS}	Dominant time required on bus for wake-up from standby	STB at V _{CC} , See Figure 12	1.5		5	μs

STB PIN CHARACTERISTICS

over recommended operating conditions including operating free-air temperature range (unless otherwise noted)

PARAMETER		TEST CONDITIONS	MIN	MAX	UNIT
I _{IH}	High-level input current	STB at V _{CC}	–10	0	μA
I _{IL}	Low-level input current	STB at 0 V	–10	0	μA

SPLIT PIN CHARACTERISTICS

over recommended operating conditions including operating free-air temperature range (unless otherwise noted)

PARAMETER		TEST CONDITIONS	MIN	TYP	MAX	UNIT
V _O	Output voltage	–500 μA < I _O < 500 μA	0.3 V _{CC}	0.5 V _{CC}	0.7 V _{CC}	V
I _{O(stb)}	Leakage current, standby mode	STB at 2 V, –12 V ≤ V _O ≤ 12 V	–5		5	μA

THERMAL CHARACTERISTICS

over recommended operating conditions including operating free-air temperature range (unless otherwise noted)

PARAMETER		TEST CONDITIONS	MIN	TYP	MAX	UNIT
θ_{JA}	Junction-to-air thermal resistance	Low-K thermal resistance ⁽¹⁾		211		°C/W
		High-K thermal resistance		131		
θ_{JB}	Junction-to-board thermal resistance			53		°C/W
θ_{JC}	Junction-to-case thermal resistance			79		°C/W
P_D	Average power dissipation	$V_{CC} = 5\text{ V}$, $T_J = 27^\circ\text{C}$, $R_L = 60\ \Omega$, STB at 0 V, Input to TXD at 500 kHz, 50% duty cycle square wave, C_L at RXD = 15 pF		112		mW
		$V_{CC} = 5.5\text{ V}$, $T_J = 130^\circ\text{C}$, $R_L = 45\ \Omega$, STB at 0 V, Input to TXD at 500 kHz, 50% duty cycle square wave, C_L at RXD = 15 pF			170	
Thermal shutdown temperature				185		°C

(1) Tested in accordance with the low-K or high-K thermal metric definitions of EIA/JESD51-3 for leaded surface-mount packages.

FUNCTION TABLES

DRIVER⁽¹⁾

INPUTS		OUTPUTS		BUS STATE
TXD	STB	CANH	CANL	
L	L	H	L	Dominant
H	L	Z	Z	Recessive
Open	L	Z	Z	Recessive
X	H or Open	Y	Y	Recessive

(1) H = high level, L = low level, X = irrelevant, ? = indeterminate, Y = weak pulldown to GND, Z = high impedance

RECEIVER⁽¹⁾

DIFFERENTIAL INPUTS $V_{ID} = V(\text{CANH}) - V(\text{CANL})$	STB	OUTPUT RXD	BUS STATE
$V_{ID} \geq 0.9\text{ V}$	L	L	Dominant
$V_{ID} \geq 1.15\text{ V}$	H or Open	L	Dominant
$0.5\text{ V} < V_{ID} < 0.9\text{ V}$	X	?	?
$V_{ID} \leq 0.5\text{ V}$	X	H	Recessive
Open	X	H	Recessive

(1) H = high level, L = low level, X = irrelevant, ? = indeterminate, Z = high impedance

PARAMETER MEASUREMENT INFORMATION

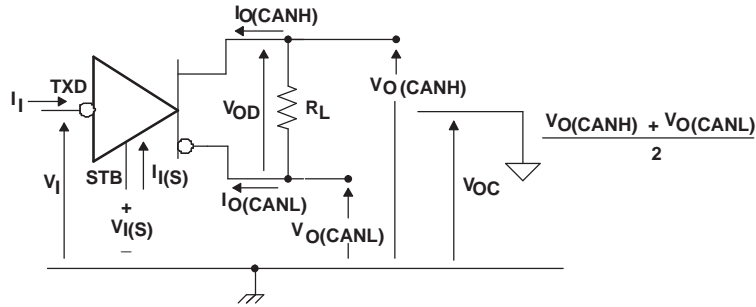

Figure 1. Driver Voltage, Current, and Test Definition

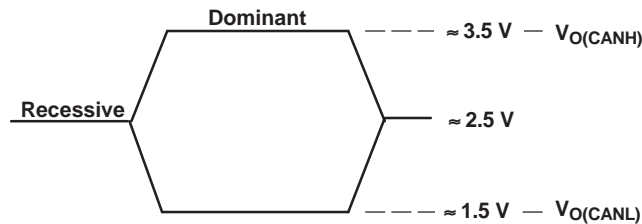

Figure 2. Bus Logic-State Voltage Definitions

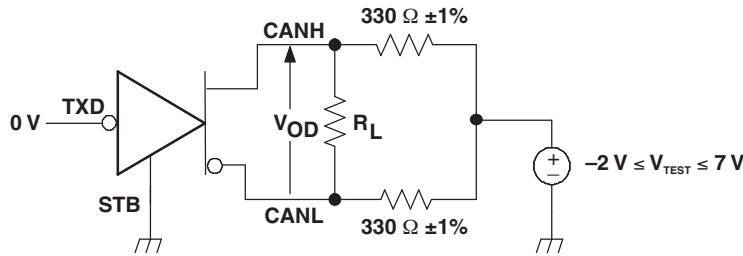

Figure 3. Driver V_{OD} Test Circuit

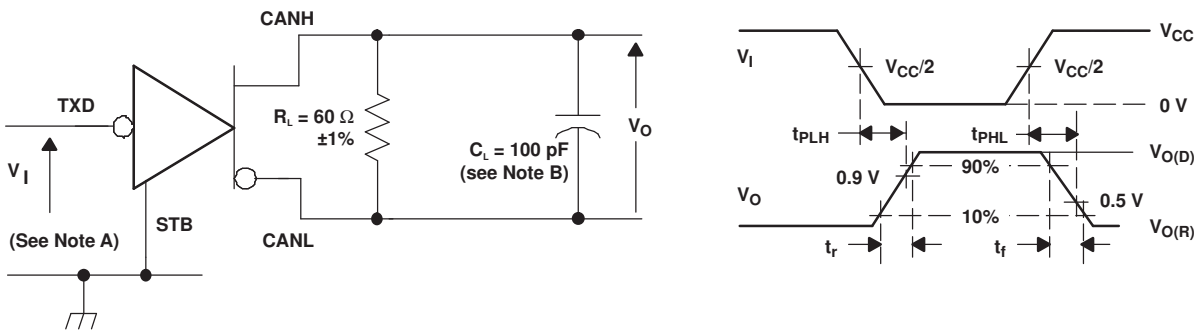

Figure 4. Driver Test Circuit and Voltage Waveforms

PARAMETER MEASUREMENT INFORMATION (continued)

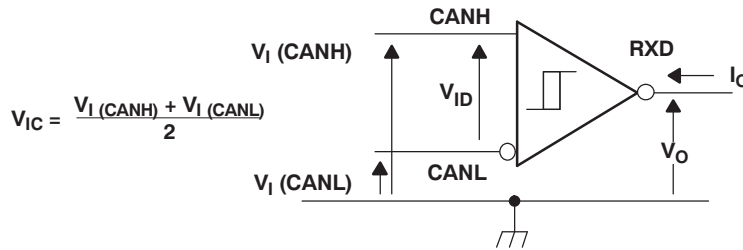
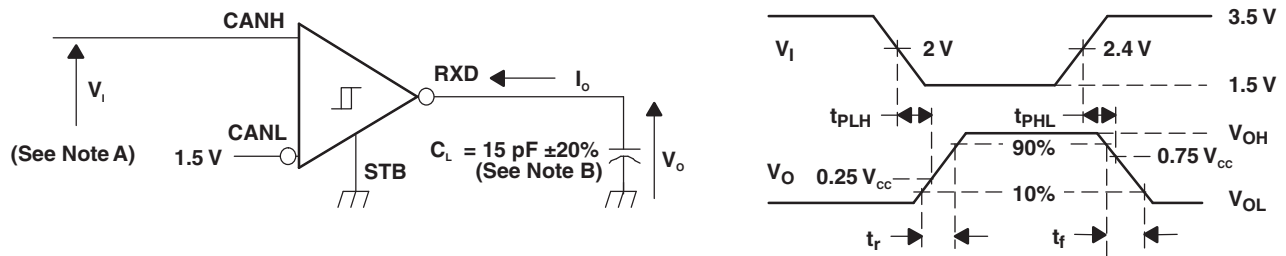

Figure 5. Receiver Voltage and Current Definitions



- A. The input pulse is supplied by a generator having the following characteristics: PRR ≤ 125 kHz, 50% duty cycle, t_r ≤ 6 ns, t_f ≤ 6 ns, Z_O = 50 Ω.
- B. C_L includes instrumentation and fixture capacitance within ±20%.

Figure 6. Receiver Test Circuit and Voltage Waveforms

Table 1. Differential Input Voltage Threshold Test

INPUT			OUTPUT	
V _{CANH}	V _{CANL}	V _{ID}	R	
-11.1 V	-12 V	900 mV	L	V _{OL}
12 V	11.1 V	900 mV	L	
-6 V	-12 V	6 V	L	
12 V	6 V	6 V	L	
-11.5 V	-12 V	500 mV	H	V _{OH}
12 V	11.5 V	500 mV	H	
-12 V	-6 V	6 V	H	
6 V	12 V	6 V	H	
Open	Open	X	H	

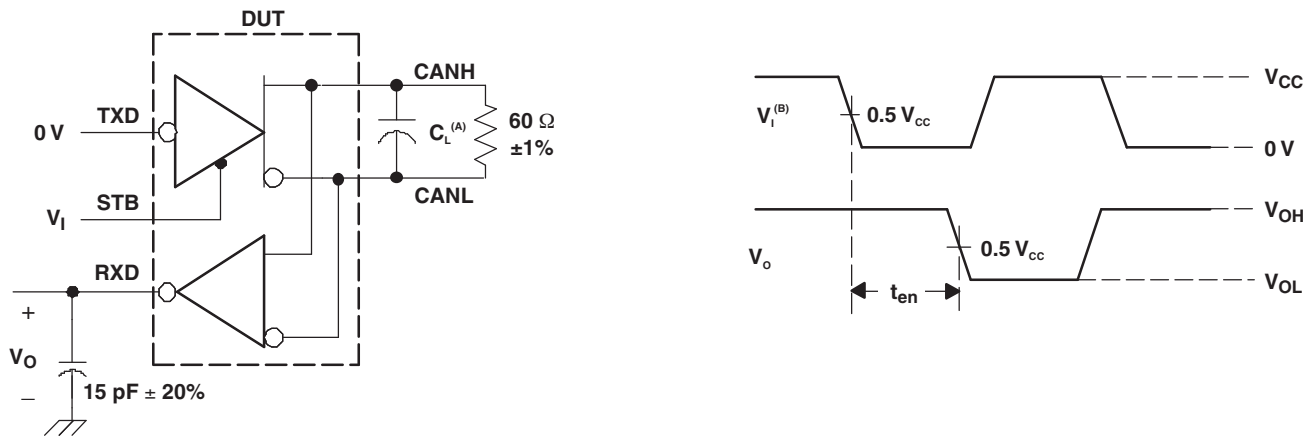

- A. $C_L = 100$ pF and includes instrumentation and fixture capacitance within $\pm 20\%$.
- B. All V_i input pulses are supplied by a generator having the following characteristics: t_r or $t_f \leq 6$ ns, pulse repetition rate (PRR) = 125 kHz, 50% duty cycle.

Figure 7. t_{en} Test Circuit and Waveforms

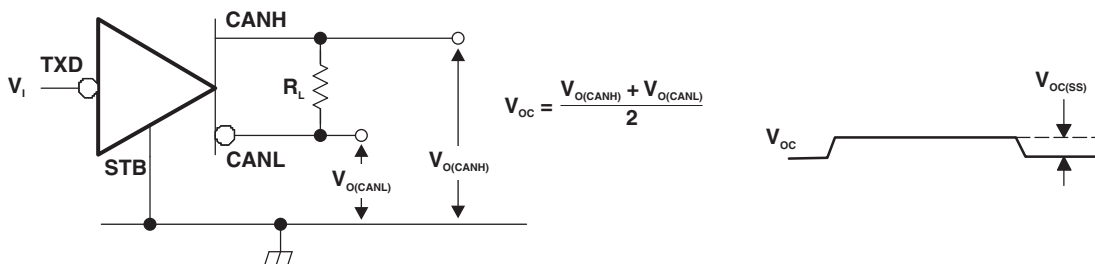

NOTE: All V_i input pulses are from 0 V to V_{CC} and supplied by a generator having the following characteristics: t_r or $t_f \leq 6$ ns, pulse repetition rate (PRR) = 125 kHz, 50% duty cycle.

Figure 8. Common-Mode Output Voltage Test and Waveforms

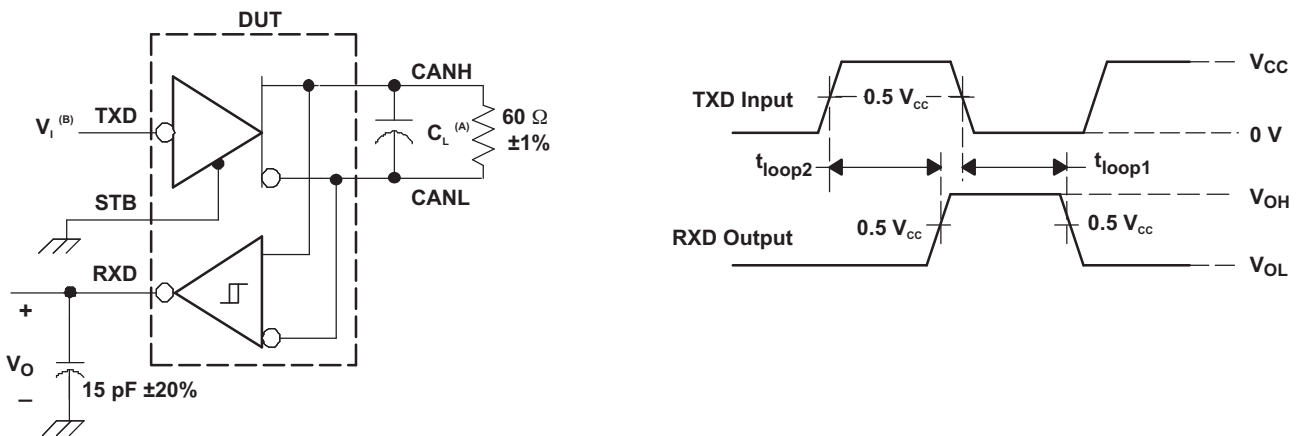

- A. $C_L = 100$ pF and includes instrumentation and fixture capacitance within $\pm 20\%$.
- B. All V_i input pulses are from 0 V to V_{CC} and supplied by a generator having the following characteristics: t_r or $t_f \leq 6$ ns, pulse repetition rate (PRR) = 125 kHz, 50% duty cycle.

Figure 9. $t_{(LOOP)}$ Test Circuit and Waveforms

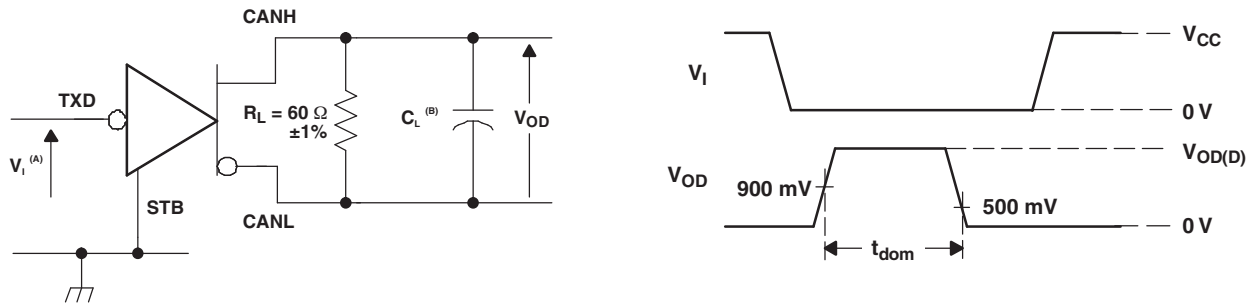

- A. All V_1 input pulses are from 0 V to V_{CC} and supplied by a generator having the following characteristics: t_r or $t_f \leq 6$ ns, pulse repetition rate (PRR) = 500 Hz, 50% duty cycle.
- B. $C_L = 100$ pF includes instrumentation and fixture capacitance within $\pm 20\%$.

Figure 10. Dominant Time-Out Test Circuit and Waveforms

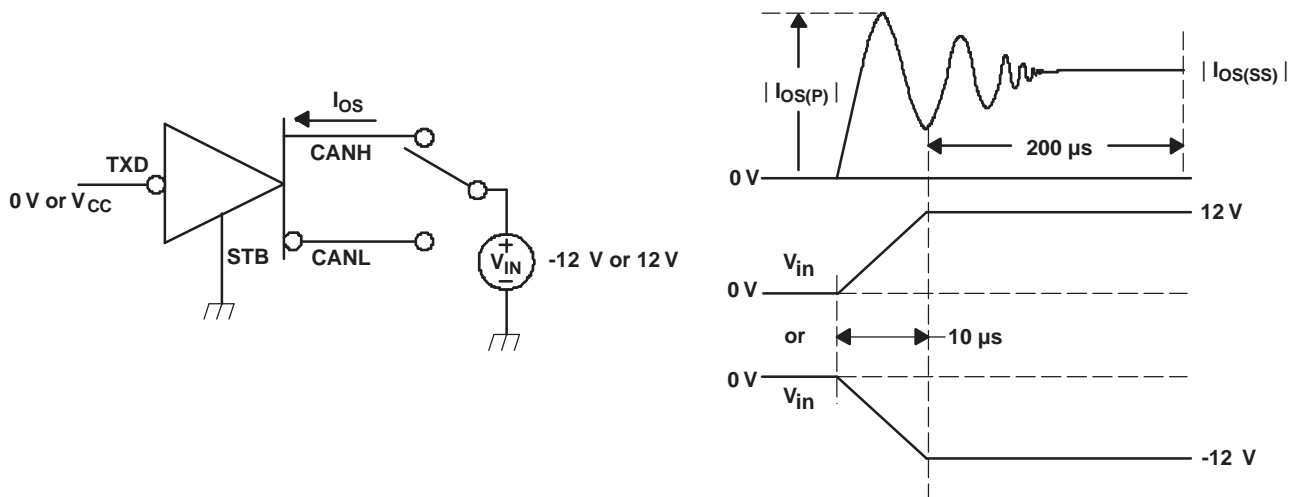
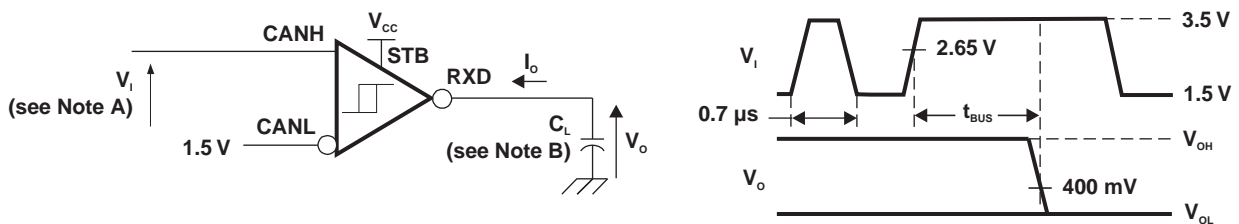
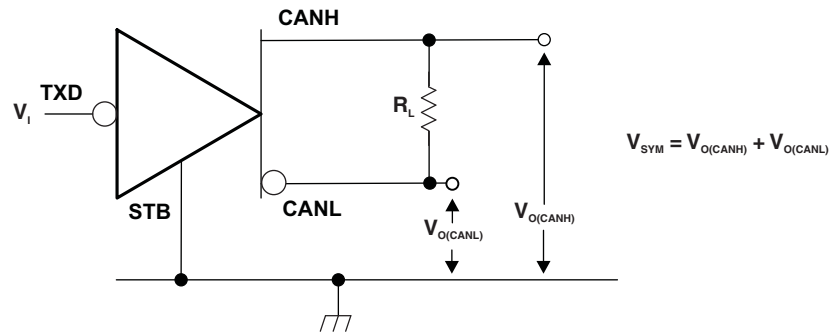

Figure 11. Driver Short-Circuit Current Test and Waveforms



- A. For V_1 bit width ≤ 0.7 μ s, $V_O = V_{OH}$. For V_1 bit width ≥ 5 μ s, $V_O = V_{OL}$. V_1 input pulses are supplied from a generator with the following characteristics: $t_r/t_f < 6$ ns.
- B. $C_L = 15$ pF and includes instrumentation and fixture capacitance within $\pm 20\%$.

Figure 12. t_{BUS} Test Circuit and Waveforms



- A. All V_I input pulses are from 0 V to V_{CC} and supplied by a generator having the following characteristics: $t_r/t_f \leq 6$ ns, pulse repetition rate (PRR) = 250 kHz, 50% duty cycle.

Figure 13. Driver Output Symmetry Test Circuit

Equivalent Input and Output Schematic Diagrams

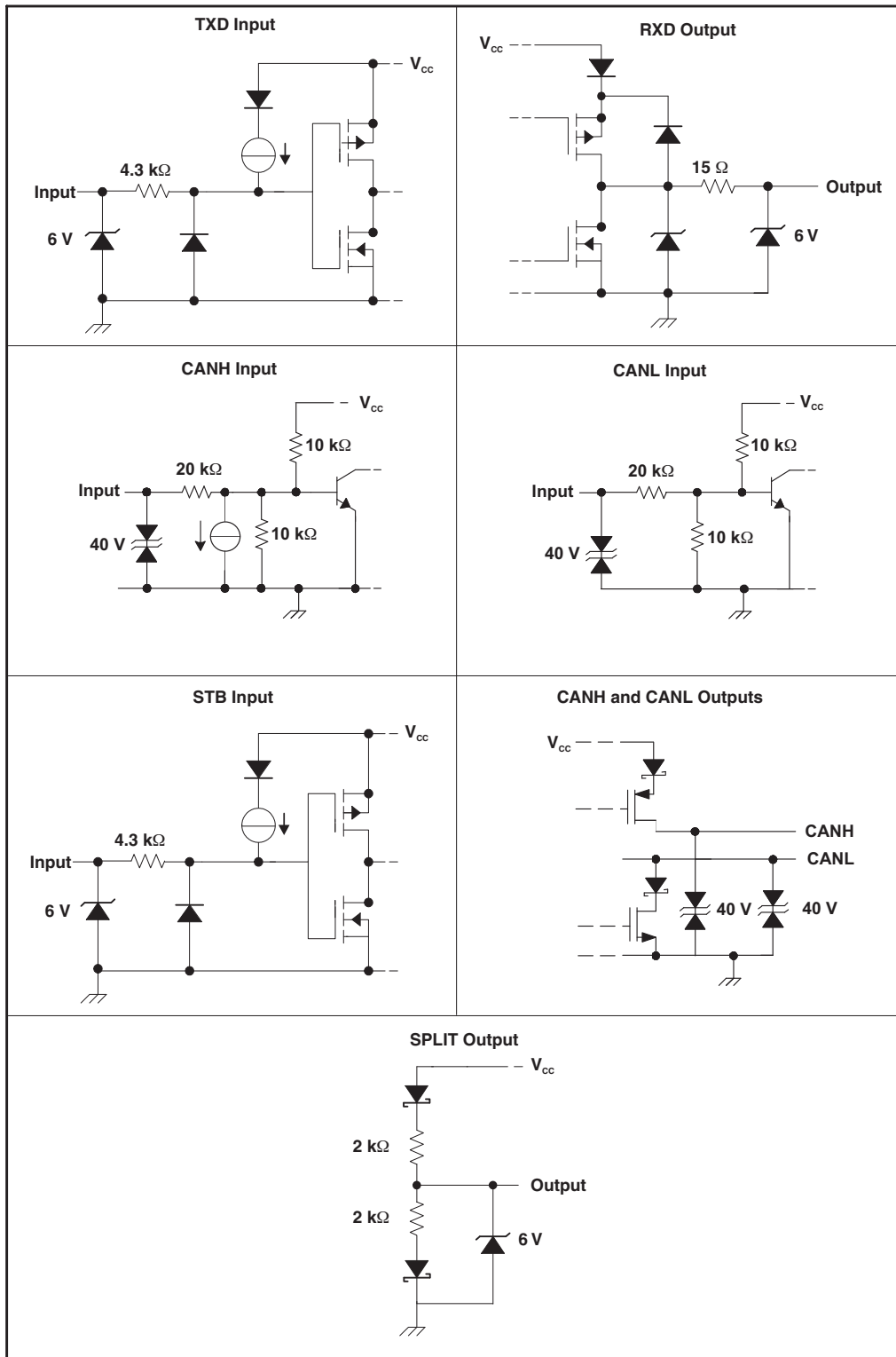

APPLICATION INFORMATION

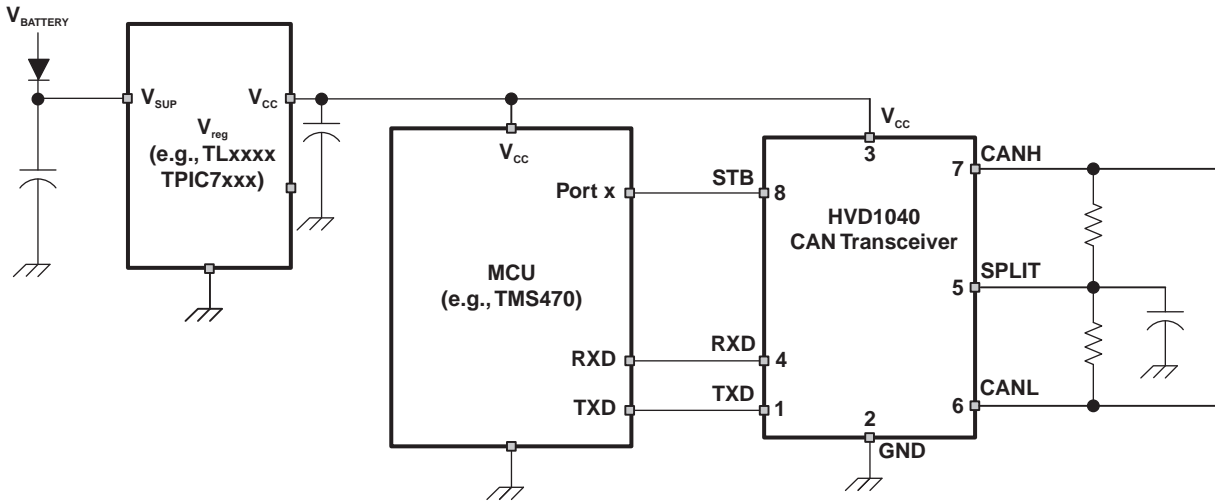

Figure 14. Typical Application Using Split Termination for Stabilization

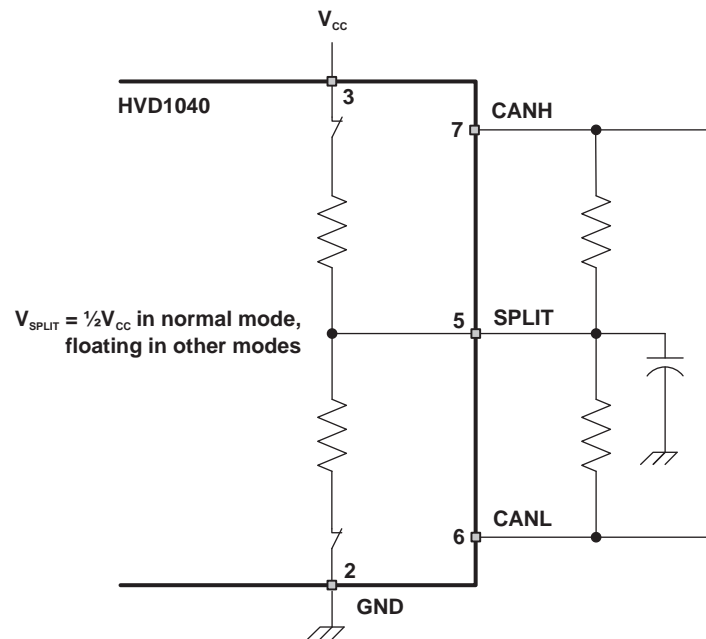

Figure 15. Split Pin Stabilization Circuitry and Application

PACKAGING INFORMATION

Orderable Device	Status ⁽¹⁾	Package Type	Package Drawing	Pins	Package Qty	Eco Plan ⁽²⁾	Lead/Ball Finish	MSL Peak Temp ⁽³⁾
SN65HVD1040QDRQ1	ACTIVE	SOIC	D	8	2500	Green (RoHS & no Sb/Br)	CU NIPDAU	Level-1-260C-UNLIM

⁽¹⁾ The marketing status values are defined as follows:

ACTIVE: Product device recommended for new designs.

LIFEBUY: TI has announced that the device will be discontinued, and a lifetime-buy period is in effect.

NRND: Not recommended for new designs. Device is in production to support existing customers, but TI does not recommend using this part in a new design.

PREVIEW: Device has been announced but is not in production. Samples may or may not be available.

OBSELETE: TI has discontinued the production of the device.

⁽²⁾ Eco Plan - The planned eco-friendly classification: Pb-Free (RoHS), Pb-Free (RoHS Exempt), or Green (RoHS & no Sb/Br) - please check <http://www.ti.com/productcontent> for the latest availability information and additional product content details.

TBD: The Pb-Free/Green conversion plan has not been defined.

Pb-Free (RoHS): TI's terms "Lead-Free" or "Pb-Free" mean semiconductor products that are compatible with the current RoHS requirements for all 6 substances, including the requirement that lead not exceed 0.1% by weight in homogeneous materials. Where designed to be soldered at high temperatures, TI Pb-Free products are suitable for use in specified lead-free processes.

Pb-Free (RoHS Exempt): This component has a RoHS exemption for either 1) lead-based flip-chip solder bumps used between the die and package, or 2) lead-based die adhesive used between the die and leadframe. The component is otherwise considered Pb-Free (RoHS compatible) as defined above.

Green (RoHS & no Sb/Br): TI defines "Green" to mean Pb-Free (RoHS compatible), and free of Bromine (Br) and Antimony (Sb) based flame retardants (Br or Sb do not exceed 0.1% by weight in homogeneous material)

⁽³⁾ MSL, Peak Temp. -- The Moisture Sensitivity Level rating according to the JEDEC industry standard classifications, and peak solder temperature.

Important Information and Disclaimer:The information provided on this page represents TI's knowledge and belief as of the date that it is provided. TI bases its knowledge and belief on information provided by third parties, and makes no representation or warranty as to the accuracy of such information. Efforts are underway to better integrate information from third parties. TI has taken and continues to take reasonable steps to provide representative and accurate information but may not have conducted destructive testing or chemical analysis on incoming materials and chemicals. TI and TI suppliers consider certain information to be proprietary, and thus CAS numbers and other limited information may not be available for release.

In no event shall TI's liability arising out of such information exceed the total purchase price of the TI part(s) at issue in this document sold by TI to Customer on an annual basis.

OTHER QUALIFIED VERSIONS OF SN65HVD1040-Q1 :

- Catalog: [SN65HVD1040](#)

NOTE: Qualified Version Definitions:

- Catalog - TI's standard catalog product

D (R-PDSO-G8)

PLASTIC SMALL-OUTLINE PACKAGE

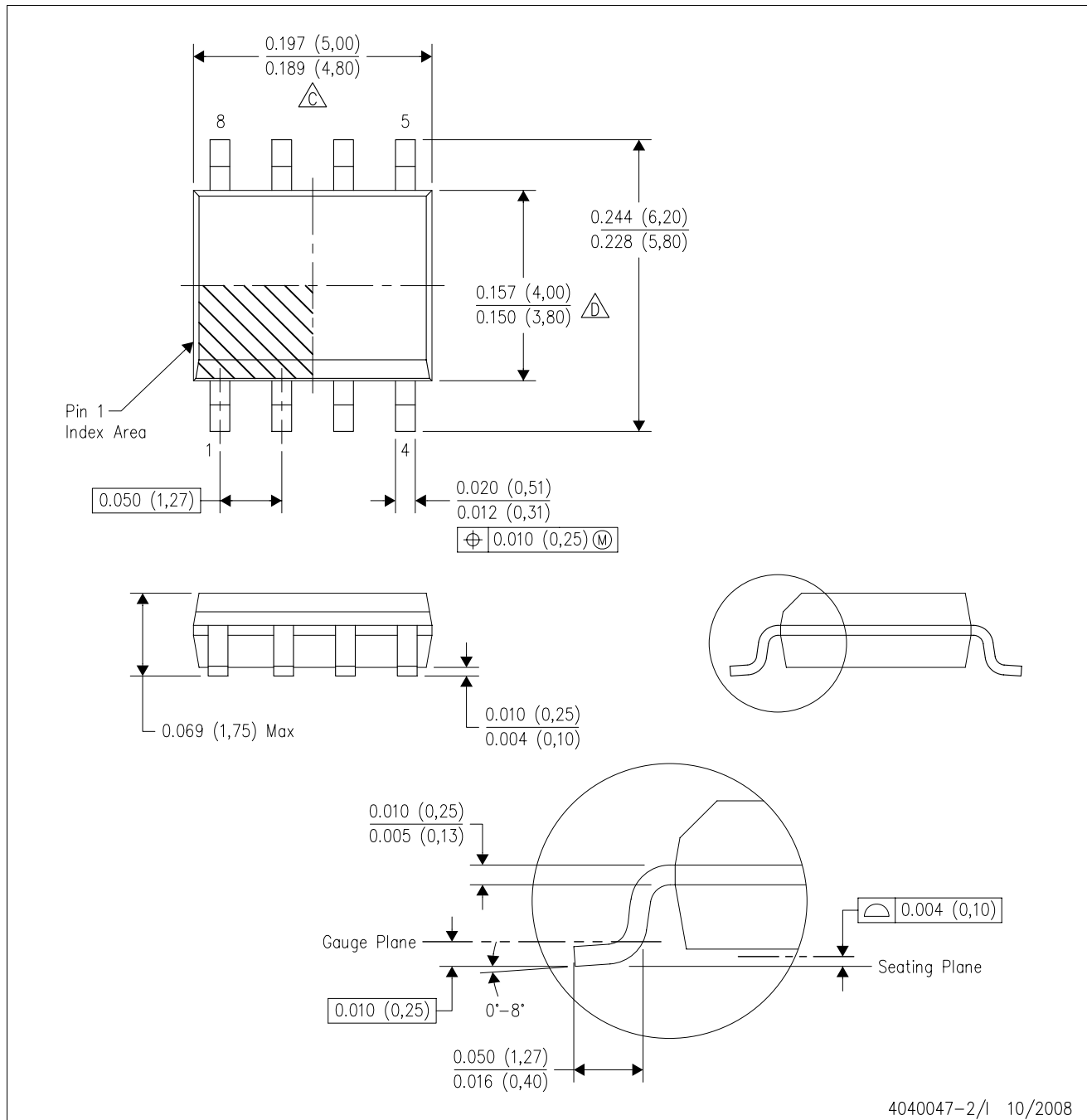

- NOTES:
- All linear dimensions are in inches (millimeters).
 - This drawing is subject to change without notice.
 - $\triangle C$ Body length does not include mold flash, protrusions, or gate burrs. Mold flash, protrusions, or gate burrs shall not exceed .006 (0,15) per end.
 - $\triangle D$ Body width does not include interlead flash. Interlead flash shall not exceed .017 (0,43) per side.
 - Reference JEDEC MS-012 variation AA.

IMPORTANT NOTICE

Texas Instruments Incorporated and its subsidiaries (TI) reserve the right to make corrections, modifications, enhancements, improvements, and other changes to its products and services at any time and to discontinue any product or service without notice. Customers should obtain the latest relevant information before placing orders and should verify that such information is current and complete. All products are sold subject to TI's terms and conditions of sale supplied at the time of order acknowledgment.

TI warrants performance of its hardware products to the specifications applicable at the time of sale in accordance with TI's standard warranty. Testing and other quality control techniques are used to the extent TI deems necessary to support this warranty. Except where mandated by government requirements, testing of all parameters of each product is not necessarily performed.

TI assumes no liability for applications assistance or customer product design. Customers are responsible for their products and applications using TI components. To minimize the risks associated with customer products and applications, customers should provide adequate design and operating safeguards.

TI does not warrant or represent that any license, either express or implied, is granted under any TI patent right, copyright, mask work right, or other TI intellectual property right relating to any combination, machine, or process in which TI products or services are used. Information published by TI regarding third-party products or services does not constitute a license from TI to use such products or services or a warranty or endorsement thereof. Use of such information may require a license from a third party under the patents or other intellectual property of the third party, or a license from TI under the patents or other intellectual property of TI.

Reproduction of TI information in TI data books or data sheets is permissible only if reproduction is without alteration and is accompanied by all associated warranties, conditions, limitations, and notices. Reproduction of this information with alteration is an unfair and deceptive business practice. TI is not responsible or liable for such altered documentation. Information of third parties may be subject to additional restrictions.

Resale of TI products or services with statements different from or beyond the parameters stated by TI for that product or service voids all express and any implied warranties for the associated TI product or service and is an unfair and deceptive business practice. TI is not responsible or liable for any such statements.

TI products are not authorized for use in safety-critical applications (such as life support) where a failure of the TI product would reasonably be expected to cause severe personal injury or death, unless officers of the parties have executed an agreement specifically governing such use. Buyers represent that they have all necessary expertise in the safety and regulatory ramifications of their applications, and acknowledge and agree that they are solely responsible for all legal, regulatory and safety-related requirements concerning their products and any use of TI products in such safety-critical applications, notwithstanding any applications-related information or support that may be provided by TI. Further, Buyers must fully indemnify TI and its representatives against any damages arising out of the use of TI products in such safety-critical applications.

TI products are neither designed nor intended for use in military/aerospace applications or environments unless the TI products are specifically designated by TI as military-grade or "enhanced plastic." Only products designated by TI as military-grade meet military specifications. Buyers acknowledge and agree that any such use of TI products which TI has not designated as military-grade is solely at the Buyer's risk, and that they are solely responsible for compliance with all legal and regulatory requirements in connection with such use.

TI products are neither designed nor intended for use in automotive applications or environments unless the specific TI products are designated by TI as compliant with ISO/TS 16949 requirements. Buyers acknowledge and agree that, if they use any non-designated products in automotive applications, TI will not be responsible for any failure to meet such requirements.

Following are URLs where you can obtain information on other Texas Instruments products and application solutions:

Products

Amplifiers	amplifier.ti.com
Data Converters	dataconverter.ti.com
DSP	dsp.ti.com
Clocks and Timers	www.ti.com/clocks
Interface	interface.ti.com
Logic	logic.ti.com
Power Mgmt	power.ti.com
Microcontrollers	microcontroller.ti.com
RFID	www.ti-rfid.com
RF/IF and ZigBee® Solutions	www.ti.com/lprf

Applications

Audio	www.ti.com/audio
Automotive	www.ti.com/automotive
Broadband	www.ti.com/broadband
Digital Control	www.ti.com/digitalcontrol
Medical	www.ti.com/medical
Military	www.ti.com/military
Optical Networking	www.ti.com/opticalnetwork
Security	www.ti.com/security
Telephony	www.ti.com/telephony
Video & Imaging	www.ti.com/video
Wireless	www.ti.com/wireless

Mailing Address: Texas Instruments, Post Office Box 655303, Dallas, Texas 75265
Copyright © 2008, Texas Instruments Incorporated